

# Ø150 AG series

x172x51mm



## General Specifications

- Motor : 4 Poles brushless DC motor
- Frame & Impeller : Al die-casting & Plastic
- Storage temperature : -40° to +75°
- Operating temperature : -10° to +70°

## Major Characteristic Parameters

Model	*Bearing System	Rated Voltage	Operating Voltage Range	Rated Current	Rated Speed	Maximum Air Flow		Maximum Static Pressure		Sound Level	Weight
Part NO.	B / S / F	V	V	A	RPM	m <sup>3</sup> /min	CFM	mm-H <sub>2</sub> O	In-H <sub>2</sub> O	dBA	g
AGE15051_24I	B	24	14.0~26.4	0.50	2500	5.29	187	8.89	0.35	52.0	610
AGE15051_48I	B	48	28.0~56.0	0.30	2500	5.29	187	8.89	0.35	52.0	610
AGE15051_24J	B	24	14.0~26.4	0.70	3500	7.44	263	20.85	0.82	57.0	610
AGE15051_48J	B	48	28.0~56.0	0.40	3500	7.44	263	20.85	0.82	57.0	610
AGE15051_24L	B	24	14.0~26.4	1.00	4000	8.24	291	23.22	0.91	61.5	610
AGE15051_48L	B	48	28.0~56.0	0.50	4000	8.24	291	23.22	0.91	61.5	610
AGE15051_24M	B	24	14.0~26.4	1.50	4400	9.14	323	26.93	1.06	63.5	610
AGE15051_48M	B	48	28.0~56.0	0.70	4400	9.14	323	26.93	1.06	63.5	610
AGE15051_24H	B	24	14.0~26.4	2.10	4800	9.90	350	31.42	1.24	65.5	610
AGE15051_48H	B	48	28.0~56.0	0.85	4800	9.90	350	31.42	1.24	65.5	610
AGE15051_24U	B	24	14.0~26.4	2.40	5200	10.70	378	34.44	1.36	68.0	610
AGE15051_48U	B	48	28.0~56.0	1.30	5200	10.70	378	34.44	1.36	68.0	610

\*Bearing system B: Two Ball Bearing F: Fluid Bearing S: Sleeve Bearing

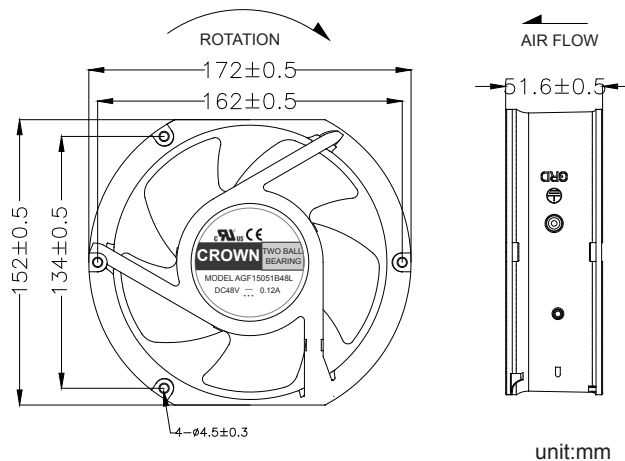
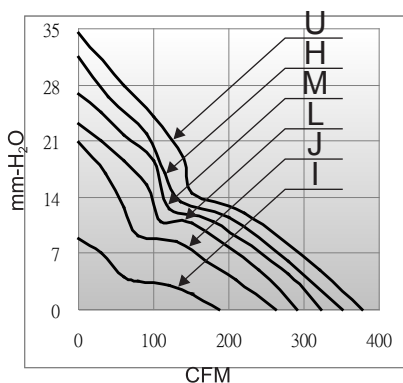

# Ø150 AG series

x172x51mm



## General Specifications

- Motor : 4 Poles brushless DC motor
- Frame & Impeller : Al die-casting & Plastic
- Storage temperature : -40° to +75°
- Operating temperature : -10° to +70°

## Major Characteristic Parameters

Model	*Bearing System	Rated Voltage	Operating Voltage Range	Rated Current	Rated Speed	Maximum Air Flow		Maximum Static Pressure		Sound Level	Weight
Part NO.	B / S / F	V	V	A	RPM	m <sup>3</sup> /min	CFM	mm-H <sub>2</sub> O	In-H <sub>2</sub> O	dBA	g
AGF15051_24J	B	24	14.0~26.4	1.50	3500	7.79	275.0	22.5	0.89	57.0	800
AGF15051_48J	B	48	28.0~56.0	0.90	3500	7.79	275.0	22.5	0.89	57.0	800
AGF15051_24L	B	24	14.0~26.4	2.10	4000	8.69	307.0	28.0	1.10	61.5	800
AGF15051_48L	B	48	28.0~56.0	1.20	4000	8.69	307.0	28.0	1.10	61.5	800
AGF15051_24M	B	24	14.0~26.4	2.88	4400	9.40	332.0	34.2	1.35	63.5	800
AGF15051_48M	B	48	28.0~56.0	1.50	4400	9.40	332.0	34.2	1.35	63.5	800

\*Bearing system B: Two Ball Bearing F: Fluid Bearing S: Sleeve Bearing

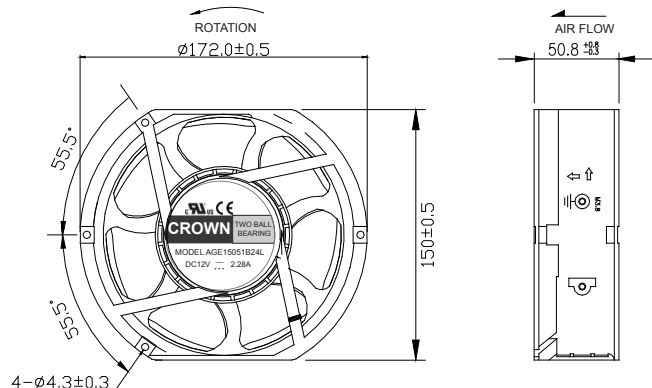
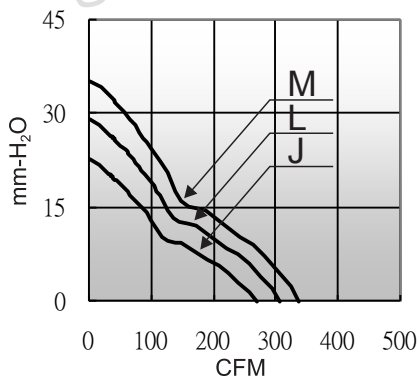

unit:mm